

HFMD

High Feed Mill Double

- Available for economical and highly efficient machining with implementation of double sided 4 corner inserts and increase in the number of teeth per cutter diameter
- Available for high speed/high feed machining with high helix edge design and excellent clamping stability

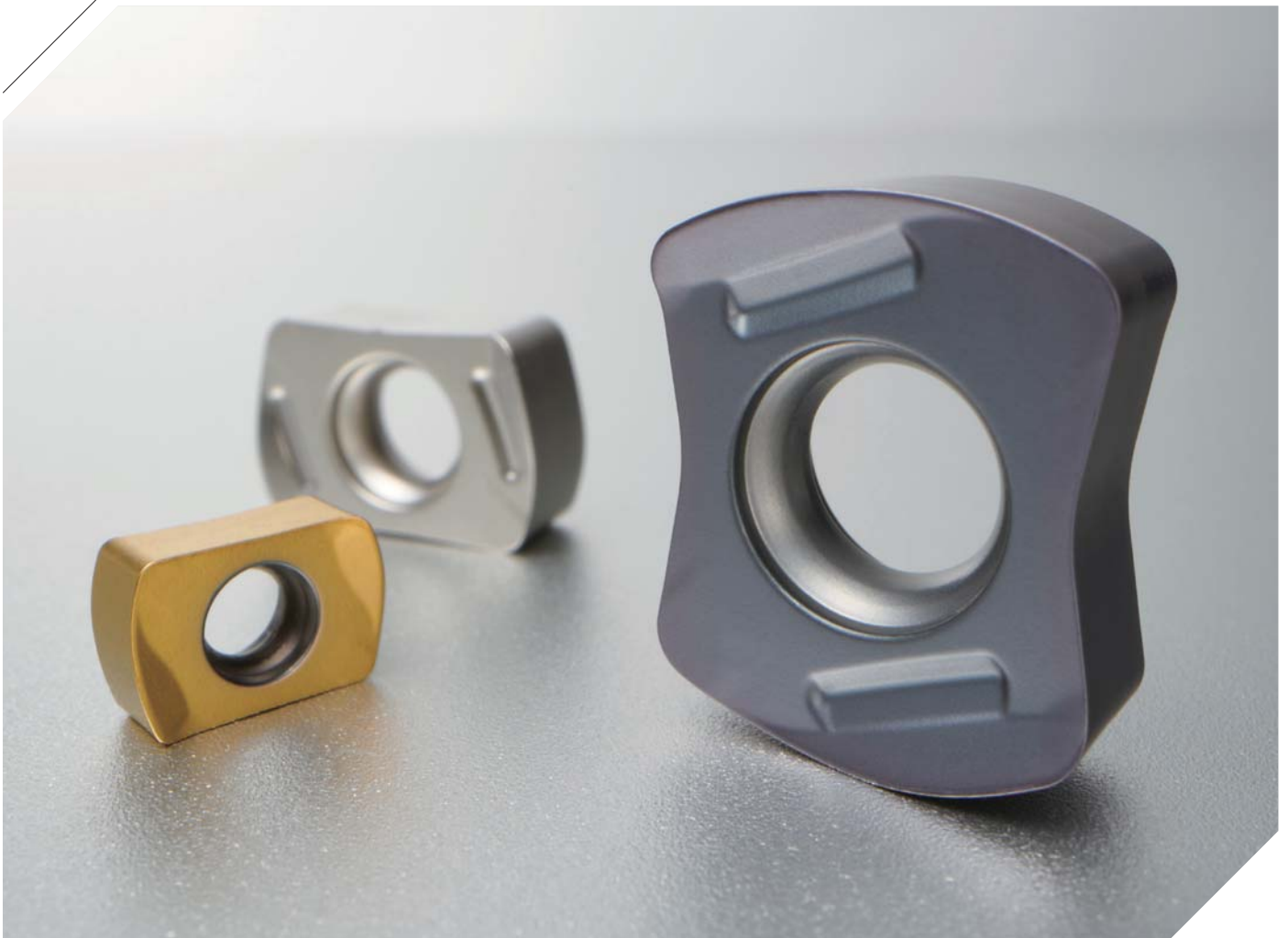

HFMD

With the development of the end-user market, the current cutting tool industry has challenges including:

First, discovering highly effective machining technologies that can improve productivity and reduce production costs within limited time and budget. Second, to find a tool/solution that can easily machine hard-to-cut materials which are becoming more widely used in numerous industries (mold, aerospace, and etc) in pursuit of durability and lighter weight.

KORLOY recommends a new high feed tool, HFMD, which can easily resolve above two challenges.

HFMD insert is a double sided 4 corner insert which is economical and enhances machining productivity by implementing more flutes per diameter. In addition, HFMD has achieved high speed/high feed machining by applying high rake angle and helix design on its edge. These two features have significantly reduced cutting resistance compared to competitors' tools or even against positive-type inserts.

Furthermore, HFMD provides excellent clamping stability by applying concave clamping system on the side, wider bottom face at the clamping area, and bigger sized screws. These will help minimize noise and vibration, prevent damage of insert with stable machining in high feed machining, and improve the surface finish of the workpiece.

As we can see in these advantages, KORLOY's HFMD is the next-generation high speed/high feed machining solution, one step ahead in the high-efficiency machining trend.

.....

» **Highly efficient and economical insert**

- Double-sided 4 corners

» **Superior clamping stability**

- Prevents insert chipping and damage by minimizing vibrations
- Improved surface finish of workpieces

» **Realization of high speed/high feed**

- High speed machining by applying high rake angle, and helix cutting edge
- Available for high feed machining with the increase in the number of teeth per cutter diameter

» **Optimized holder design**

- Excellent chip evacuation in slotting or deep shouldering with minimized interference with side walls



Code system

Shank type

HFMD	S	025	R	-	4	C	25	-	180	-	LN06
HFMD	Type S: Shank	Machining diameter 025: Ø25 mm	Oil hole & Hand R: With oil hole, Right-handed NR: Without oil hole, Right-handed		No. of tooth 4: 4 teeth	Shank type W: Weldon C: Cylinder	Shank diameter 25: Ø25 mm		Overall length 180: 180 mm		Available inserts LN04: LNMX04 LN06: LNMX06 LN10: LNMX10

Cutter type

HFMD	C	M	063	R	-	22	-	8	-	LN10
HFMD	Type C: Cutter	Arbor type M: Metric A: Inch None: Asia	Machining diameter 063: Ø63 mm	Oil hole & Hand R: With oil hole, Right-handed NR: Without oil hole, Right-handed		Internal diameter 22: Ø22 mm		No. of tooth 8: 8 teeth		Available inserts LN06: LNMX06 LN10: LNMX10



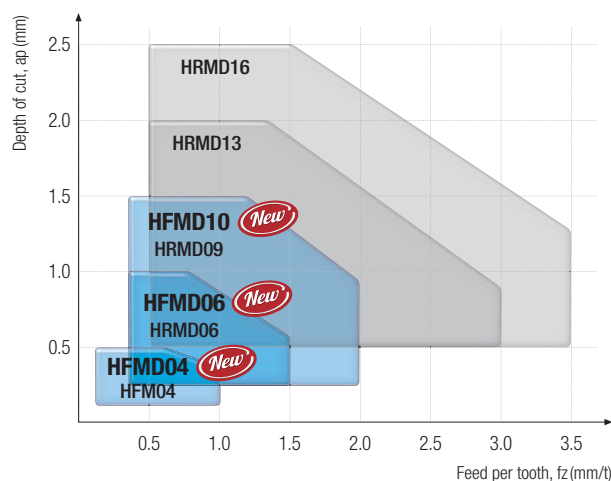
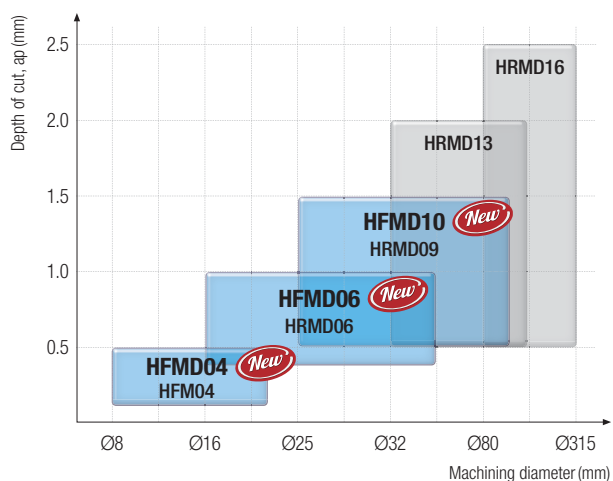

Modular type

HFMD	M	016	R	-	4	-	M08	-	LN04
HFMD	Type M: Modular	Machining diameter 016: Ø16 mm	Oil hole & Hand R: With oil hole, Right-handed NR: Without oil hole, Right-handed		No. of tooth 4: 4 teeth		M Dimensions		Available inserts LN04: LNMX04 LN06: LNMX06 LN10: LNMX10

Application range

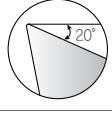

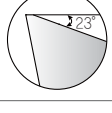
Application and features of chip breakers

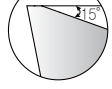
Chip breakers	Cutting-edge	Application	Features	
ML			For heat resistant alloy and titanium	Ensures superior machining quality by applying a low cutting resistance chip breaker and high-strength cutting edge design suitable for machining heat resistant alloy
MF			For light cutting	Suitable for light cutting with a low cutting resistance chip breaker design
MM			For multi-purpose	Available for most cutting area with its exclusive design suitable for general high feed machining

High feed tool selection guide

—○— HFMD
 —○— HFM
 —○— HRM
 —○— HRMD

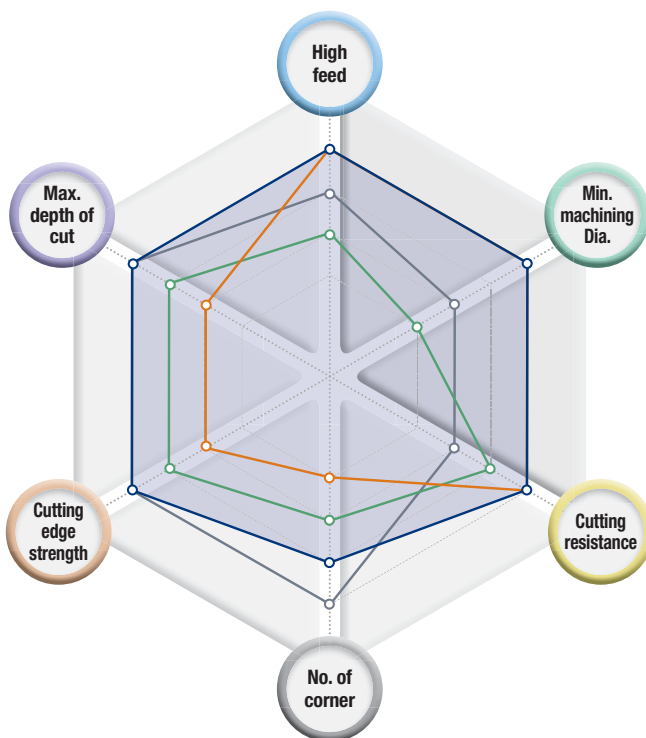

HFMD New!

- To increase productivity
- To machine workpiece with more edges
- Min. Ø8 mm machining



HFM

- To machine smaller diameter
- Min. Ø8 mm machining



HRM

- For general machining
- Single-sided 3 corners machining



HRMD

- To focus on economical feasibility
- Double-sided 6 corners machining



Tools	High feed	Min. machining Dia.	Cutting resistance	No. of corner	Cutting edge strength	Max. depth of cut
HFMD New!	★★★★★	★★★★★	★★★★★	★★★	★★★★★	★★★★★
HFM	★★★★★	★★★★★	★★★★★	★	★★	★★
HRM	★★	★	★★★	★★	★★★	★★★
HRMD	★★★	★★	★★	★★★★★	★★★★★	★★★★★

Recommended cutting conditions_HFMD04

N/mm²: Specific cutting force Kc1

Workpiece						PC5300			PC3700			PC2510		PC2505		ML, MM
ISO	Workpiece materials	ISO	AISI	N/mm²	HB (HrC)	vc	ML	MM	vc	ML	MM	vc	MM	vc	MM	ap (mm)
						(m/min)	fz (mm/t)	(m/min)	fz (mm/t)	(m/min)	fz (mm/t)	(m/min)	fz (mm/t)			
P	Mild steel	C22	1020	1500	125	160	1.2	1.2	160	1.0	1.0	-	-	-	-	0.2~0.5
						180	1.0	1.0	200	0.8	0.8	-	-	-	-	
						200	0.8	0.8	240	0.6	0.6	-	-	-	-	
	Carbon steel	C45	1045	1700	190	160	1.2	1.2	160	1.0	1.0	-	-	-	-	0.2~0.5
						180	1.0	1.0	200	0.8	0.8	-	-	-	-	
						200	0.8	0.8	240	0.6	0.6	-	-	-	-	
	Alloy steel	41CrMo4	4140	1700	175	160	-	1.2	180	-	1.0	-	-	-	-	0.2~0.5
						180	-	1.0	200	-	0.8	-	-	-	-	
						200	-	0.8	220	-	0.6	-	-	-	-	
	Pre-hardened steel	36CrNiMo6 (Improved)	4340 (Improved)	2020	330	140	-	1.0	160	-	0.8	-	-	-	-	0.2~0.4
						160	-	0.9	180	-	0.7	-	-	-	-	
						180	-	0.8	200	-	0.6	-	-	-	-	
		36CrNiMo6 (Improved)	4340 (Improved)	2020	360	140	-	1.0	160	-	0.8	-	-	-	-	0.2~0.4
						160	-	0.9	180	-	0.7	-	-	-	-	
						180	-	0.8	200	-	0.6	-	-	-	-	
		36CrNiMo6 (Improved)	4340 (Improved)	2020	400	120	-	1.0	-	-	-	-	-	-	-	0.2~0.4
						140	-	0.9	-	-	-	-	-	-	-	
						160	-	0.8	-	-	-	-	-	-	-	
		X20Cr13	420	2300	330	100	-	0.7	140	-	0.7	-	-	-	-	0.2~0.4
	120					-	0.6	150	-	0.6	-	-	-	-		
140	-					0.5	160	-	0.5	-	-	-	-			
Alloy tool steel	X40CrMoV5-1	H13	2300	(38)	-	-	-	-	-	-	110	0.7	110	0.7	0.2~0.3	
					-	-	-	-	-	-	120	0.6	120	0.6		
					-	-	-	-	-	-	130	0.5	130	0.5		

Workpiece						PC5300		PC9540		UPC845		UNC840		ML
ISO	Workpiece materials	ISO	AISI	N/mm²	HB (HrC)	vc	ML	vc	ML	vc	ML	vc	ML	ap (mm)
						(m/min)	fz (mm/t)	(m/min)	fz (mm/t)	(m/min)	fz (mm/t)	(m/min)	fz (mm/t)	
M	Ferritic/martensitic	X10CrAl13 X10CrAl18	405 430	1800	200	120	1.0	120	1.0	120	1.0	120	1.0	0.2~0.5
						160	0.8	160	0.8	160	0.8	160	0.8	
						200	0.6	200	0.6	200	0.6	200	0.6	
		X12CrS13 X6CrMo17-1	416 434	2800	330	100	1.0	100	1.0	100	1.0	100	1.0	0.2~0.5
						140	0.8	140	0.8	140	0.8	140	0.8	
						180	0.6	180	0.6	180	0.6	180	0.6	
	X6Cr13 X10Cr13	403 410	2300	330	100	1.0	100	1.0	100	1.0	100	1.0	0.2~0.5	
					140	0.8	140	0.8	140	0.8	140	0.8		
					180	0.6	180	0.6	180	0.6	180	0.6		
	Austenitic	5CrNi18-10 X5CrNiMo17-12-2	304 316	2000	200	100	0.8	100	0.8	100	0.8	100	0.8	0.2~0.4
130						0.7	120	0.7	120	0.7	130	0.7		
160						0.6	140	0.6	140	0.6	160	0.6		
Austenitic/ferritic (Duplex)	X2CrNiMoN22-53	S31803 S32750	2400	260	60	0.7	60	0.7	60	0.7	60	0.7	0.2~0.3	
					90	0.6	90	0.6	90	0.6	90	0.6		
					120	0.5	120	0.5	120	0.5	120	0.5		

Workpiece						PC5300			MM
ISO	Workpiece materials	ISO	AISI	N/mm²	HB (HrC)	vc	MM		ap (mm)
						(m/min)	fz (mm/t)	ap (mm)	
K	Gray cast iron	200 EN-GJL-200	No 30 B	900	180	120	1.0		0.2~0.5
						160	0.8		
						200	0.6		
	Nodular graphite cast iron	500-7 EN-GJS-800-7	80-55-06	870	155	110	1.0		0.2~0.5
						145	0.8		
						0.6			

Workpiece						UPC845			UNC840			ML, MM
ISO	Workpiece materials	ISO	AISI	N/mm²	HB (HrC)	vc	ML	MM	vc	ML	MM	ap (mm)
						(m/min)	fz (mm/t)	(m/min)	fz (mm/t)	(m/min)	fz (mm/t)	
S	Nickel based	15156-3	15156-3	2650	250	25	-	0.7	30	-	0.7	0.2~0.3
						40	-	0.5	45	-	0.5	
						55	-	0.3	60	-	0.3	
		9723	9723	2900	350	20	-	0.7	25	-	0.7	0.2~0.3
						35	-	0.5	40	-	0.5	
						50	-	0.3	55	-	0.3	
	Cobalt based alloy	Stellite	Stellite	3000	300	20	0.7	-	30	0.7	-	0.2~0.3
						35	0.5	-	45	0.5	-	
						50	0.3	-	60	0.3	-	
	Titanium alloy steel	TiAl6V4	-	1400	320	20	0.8	-	30	0.8	-	0.2~0.3
40						0.6	-	50	0.6	-		
60						0.4	-	70	0.4	-		

Recommended cutting conditions_HFMD06

N/mm²: Specific cutting force Kc1

Workpiece						PC5400		PC5300			PC3700			PC2510		PC2505		ML, MF, MM	
ISO	Workpiece materials	ISO	AISI	N/mm²	HB (HRC)	vc	ML	vc	MF	MM	vc	MF	MM	vc	MM	vc	MM	ap (mm)	
						(m/min)	fz (mm/t)	(m/min)	fz (mm/t)	(m/min)	fz (mm/t)	(m/min)	fz (mm/t)	(m/min)	fz (mm/t)	(m/min)	fz (mm/t)		
P	Mild steel	C22	1020	1500	125	160	1.0	160	1.2	1.2	-	-	-	-	-	-	-	0.2~1.0	
						200	0.8	180	1.0	1.0	-	-	-	-	-	-	-		
						240	0.6	200	0.8	0.8	-	-	-	-	-	-	-		-
	Carbon steel	C45	1045	1700	190	160	1.0	160	1.2	1.2	180	1.2	-	-	-	-	-	0.2~1.0	
						200	0.8	180	1.0	1.0	200	1.0	-	-	-	-	-		
						240	0.6	200	0.8	0.8	220	0.8	-	-	-	-	-		-
	Alloy steel	41CrMo4	4140	1700	175	-	-	160	1.0	1.2	180	1.0	1.2	-	-	-	-	0.2~1.0	
						-	-	180	0.8	1.0	200	0.8	1.0	-	-	-	-		
						-	-	200	0.6	0.8	220	0.6	0.8	-	-	-	-		-
	Pre-hardened steel	36CrNiMo6 (Improved)	4340 (Improved)	2020	330	-	-	140	0.8	1.0	160	0.8	1.0	-	-	-	-	0.2~0.8	
						-	-	160	0.7	0.9	180	0.7	0.9	-	-	-	-		
						-	-	180	0.6	0.8	200	0.6	0.8	-	-	-	-		
						-	-	140	0.8	1.0	160	0.8	1.0	-	-	-	-		
		36CrNiMo6 (Improved)	4340 (Improved)	2020	360	-	-	160	0.7	0.9	180	0.7	0.9	-	-	-	-	-	0.2~0.8
						-	-	180	0.6	0.8	200	0.6	0.8	-	-	-	-		
						-	-	120	0.8	1.0	-	-	-	-	-	-	-		
						-	-	160	0.6	0.8	-	-	-	-	-	-	-		
	36CrNiMo6 (Improved)	4340 (Improved)	2020	400	-	-	140	0.7	0.9	-	-	-	-	-	-	-	-	0.2~0.8	
					-	-	160	0.6	0.8	-	-	-	-	-	-				
					-	-	100	-	0.8	140	0.8	0.8	-	-	-	-			
-					-	120	-	0.7	150	0.7	0.7	-	-	-	-				
X20Cr13	420	2300	330	-	-	140	0.6	0.8	160	0.6	0.6	-	-	-	-	-	0.2~0.8		
				-	-	120	-	0.6	150	0.7	0.7	-	-	-	-				
				-	-	140	-	0.6	160	0.6	0.6	-	-	-	-				
				-	-	-	-	-	-	-	-	110	0.8	110	0.8				
Alloy tool steel	X40CrMoV5-1	H13	2300	(38)	-	-	-	-	-	-	-	-	120	0.7	120	0.7	0.2~0.6		
					-	-	-	-	-	-	-	-	130	0.6	130	0.6			
					-	-	-	-	-	-	-	-	-	-	-	-			

Workpiece						PC5400		PC9540		UPC845		UNC840		ML		
ISO	Workpiece materials	ISO	AISI	N/mm²	HB (HRC)	vc	ML	vc	ML	vc	ML	vc	ML	ap (mm)		
						(m/min)	fz (mm/t)	(m/min)	fz (mm/t)	(m/min)	fz (mm/t)	(m/min)	fz (mm/t)			
M	Ferritic/martensitic	X10CrAl13 X10CrAl18	405 430	1800	200	120	1.0	120	1.0	120	1.0	120	1.0	0.2~1.0		
						160	0.8	160	0.8	160	0.8	160	0.8			
						200	0.6	200	0.6	200	0.6	200	0.6			
		X12CrS13 X6CrMo17-1	416 434	2800	330	100	1.0	100	1.0	100	1.0	100	1.0	100	1.0	0.2~1.0
						140	0.8	140	0.8	140	0.8	140	0.8			
						180	0.6	180	0.6	180	0.6	180	0.6			
	X6Cr13 X10Cr13	403 410	2300	330	100	1.0	100	1.0	100	1.0	100	1.0	100	1.0	0.2~1.0	
					140	0.8	140	0.8	140	0.8	140	0.8				
					180	0.6	180	0.6	180	0.6	180	0.6				
	Austenitic	X5CrNi18-10 X5CrNiMo17-12-2	304 316	2000	200	100	0.8	100	0.8	100	0.8	100	0.8	0.2~0.8		
130						0.7	120	0.7	120	0.7	130	0.7				
160						0.6	140	0.6	140	0.6	160	0.6				
Austenitic/ferritic (Duplex)	X2CrNiMoN22-53	S31803 S32750	2400	260	60	0.7	60	0.7	60	0.7	60	0.7	0.2~0.6			
					90	0.6	90	0.6	90	0.6	90	0.6				
					120	0.5	120	0.5	120	0.5	120	0.5				

Workpiece						PC5300				MF, MM	
ISO	Workpiece materials	ISO	AISI	N/mm²	HB (HRC)	vc (m/min)	MF		MM		ap (mm)
							fz (mm/t)				
K	Gray cast iron	200 EN-GJL-200	No 30 B	900	180	120	1.0		1.0		0.2~1.0
						160	0.8		0.8		
						200	0.6		0.6		
	Nodular graphite cast iron	500-7 EN-GJS-800-7	80-55-06	870	155	110	1.0		1.0		0.2~1.0
						145	0.8		0.8		
-	-	-	-	-	-	0.6		0.6		-	

Workpiece						UPC845			UNC840			ML, MF
ISO	Workpiece materials	ISO	AISI	N/mm²	HB (HRC)	vc (m/min)	ML	MF	vc (m/min)	ML	MF	ap (mm)
							fz (mm/t)					
S	Nickel based	15156-3	15156-3	2650	250	25	-	0.7	30	-	0.7	0.2~0.6
						40	-	0.5	45	-	0.5	
						55	-	0.3	60	-	0.3	
		9723	9723	2900	350	20	-	0.7	25	-	0.7	0.2~0.6
						35	-	0.5	40	-	0.5	
						50	-	0.3	55	-	0.3	
	Cobalt based alloy	Stellite	Stellite	3000	300	20	0.7	-	30	0.7	-	0.2~0.6
						35	0.5	-	45	0.5	-	
						50	0.3	-	60	0.3	-	
	Titanium alloy steel	TiAl6V4	-	1400	320	20	1.0	-	30	1.0	-	0.2~0.6
40						0.8	-	50	0.8	-		
60						0.6	-	70	0.6	-		

Recommended cutting conditions_HFMD10

N/mm²: Specific cutting force Kc1

Workpiece						PC5400		PC5300			PC3700			PC2510		PC2505		ML, MF, MM
ISO	Workpiece materials	ISO	AISI	N/mm²	HB (HRC)	vc	ML	vc	MF	MM	vc	MF	MM	vc	MM	vc	MM	ap (mm)
						(m/min)	fz (mm/t)	(m/min)	fz (mm/t)	(m/min)	fz (mm/t)	(m/min)	fz (mm/t)	(m/min)	fz (mm/t)	(m/min)	fz (mm/t)	
P	Mild steel	C22	1020	1500	125	160	1.2	160	1.2	1.4	-	-	-	-	-	-	-	0.3~1.5
						200	1.0	200	1.0	1.2	-	-	-	-	-	-		
						240	0.8	240	0.8	1.0	-	-	-	-	-	-		
	Carbon steel	C45	1045	1700	190	160	1.2	160	1.2	1.4	160	1.4	1.4	-	-	-	-	0.3~1.5
						200	1.0	200	1.0	1.2	200	1.2	-	-	-	-		
						240	0.8	240	0.8	1.0	240	1.0	-	-	-	-		
	Alloy steel	41CrMo4	4140	1700	175	-	-	160	1.2	1.4	180	1.2	1.4	-	-	-	-	0.3~1.5
						-	-	180	1.0	1.2	200	1.0	1.2	-	-	-		
						-	-	200	0.8	1.0	220	0.8	1.0	-	-	-		
	Pre-hardened steel	36CrNiMo6 (Improved)	4340 (Improved)	2020	330	-	-	140	1.0	1.2	160	1.0	1.2	-	-	-	-	0.3~1.2
						-	-	160	0.9	1.0	180	0.9	1.0	-	-	-		
						-	-	180	0.8	0.8	200	0.8	0.8	-	-	-		
		36CrNiMo6 (Improved)	4340 (Improved)	2020	360	-	-	140	1.0	1.2	160	1.0	1.2	-	-	-	-	0.3~1.2
						-	-	160	0.9	1.0	180	0.9	1.0	-	-	-		
						-	-	180	0.8	0.8	200	0.8	0.8	-	-	-		
		36CrNiMo6 (Improved)	4340 (Improved)	2020	400	-	-	140	1.0	1.2	-	-	-	-	-	-	-	0.3~1.2
						-	-	160	0.9	1.0	-	-	-	-	-	-		
						-	-	180	0.8	0.8	-	-	-	-	-	-		
		X20Cr13	420	2300	330	-	-	100	-	0.8	140	0.9	0.9	-	-	-	-	0.3~1.2
						-	-	120	-	0.7	150	0.8	0.8	-	-	-		
-						-	140	-	0.6	160	0.7	0.7	-	-	-			
Alloy tool steel	X40CrMoV5-1	H13	2300	(38)	-	-	-	-	-	-	-	-	130	0.9	130	0.9	0.3~0.9	
					-	-	-	-	-	-	-	-	140	0.8	140	0.8		
					-	-	-	-	-	-	-	-	150	0.7	150	0.7		

Workpiece						PC5400		PC9540		UPC845		UNC840		ML		
ISO	Workpiece materials	ISO	AISI	N/mm²	HB (HRC)	vc	ML	vc	ML	vc	ML	vc	ML	ap (mm)		
						(m/min)	fz (mm/t)	(m/min)	fz (mm/t)	(m/min)	fz (mm/t)	(m/min)	fz (mm/t)			
M	Ferritic/martensitic	X10CrAl13 X10CrAl18	405 430	1800	200	120	1.2	120	1.2	120	1.2	120	1.2	0.3~1.5		
						160	1.0	160	1.0	160	1.0	160	1.0			
						200	0.8	200	0.8	200	0.8	200	0.8			
		X12CrS13 X6CrMo17-1	416 434	2800	330	100	1.2	100	1.2	100	1.2	100	1.2	100	1.2	0.3~1.5
						140	1.0	140	1.0	140	1.0	140	1.0			
						180	0.8	180	0.8	180	0.8	180	0.8			
	X6Cr13 X10Cr13	403 410	2300	330	100	1.2	100	1.2	100	1.2	100	1.2	100	1.2	0.3~1.5	
					140	1.0	140	1.0	140	1.0	140	1.0				
					180	0.8	180	0.8	180	0.8	180	0.8				
	Austenitic	X5CrNi18-10 X5CrNiMo17-12-2	304 316	2000	200	100	1.0	100	1.0	100	1.0	100	1.0	0.3~1.2		
						130	0.9	120	0.9	120	0.9	130	0.9			
						160	0.8	140	0.8	140	0.8	160	0.8			
Austenitic/ferritic (Duplex)	X2CrNiMoN22-53	S31803 S32750	2400	260	60	0.9	60	0.9	60	0.9	60	0.9	0.3~1.0			
					90	0.8	90	0.8	90	0.8	90	0.8				
					120	0.7	120	0.7	120	0.7	120	0.7				

Workpiece						PC5300			MF, MM
ISO	Workpiece materials	ISO	AISI	N/mm²	HB (HRC)	vc (m/min)	MF	MM	ap (mm)
							fz (mm/t)		
K	Gray cast iron	200 EN-GJL-200	No 30 B	900	180	120	1.2	1.2	0.3~1.5
						160	1.0	1.0	
						200	0.8	0.8	
	Nodular graphite cast iron	500-7 EN-GJS-800-7	80-55-06	870	155	110	1.2	1.2	0.3~1.5
145						1.0	1.0		
180						0.8	0.8		

Workpiece						UPC845			UNC840			ML, MF
ISO	Workpiece materials	ISO	AISI	N/mm²	HB (HRC)	vc (m/min)	ML	MF	vc (m/min)	ML	MF	ap (mm)
							fz (mm/t)			fz (mm/t)		
S	Nickel based	15156-3	15156-3	2650	250	30	-	0.8	25	-	0.8	0.3~0.9
						45	-	0.6	40	-	0.6	
						60	-	0.4	55	-	0.4	
		25	-	0.8	20	-	0.8					
		40	-	0.6	35	-	0.6					
		55	-	0.4	50	-	0.4					
	Cobalt based alloy	Stellite	Stellite	3000	300	30	0.8	-	20	0.8	-	0.3~0.9
						45	0.6	-	35	0.6	-	
						60	0.4	-	50	0.4	-	
						30	1.0	-	20	1.0	-	
Titanium alloy steel	TiAl6V4	-	1400	320	50	0.8	-	40	0.8	-	0.3~0.9	
					70	0.6	-	60	0.6	-		

[HFMD04]

P Steel

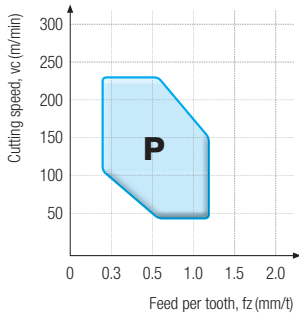

M Stainless steel

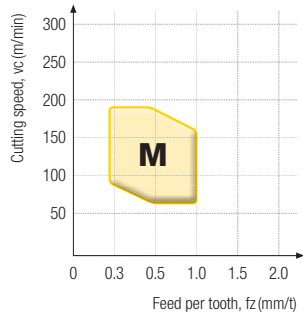

K Cast iron

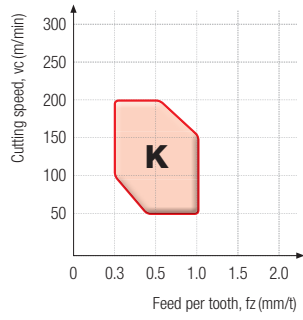

S HRSA

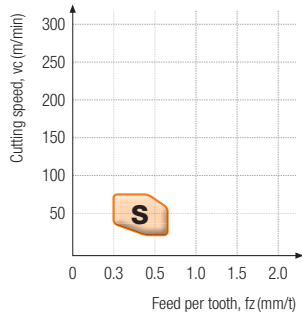

[HFMD06]

P Steel

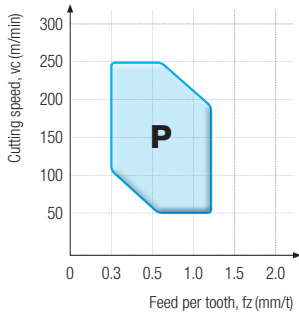

M Stainless steel

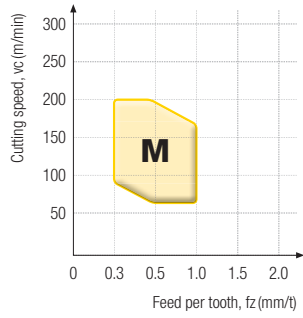

K Cast iron

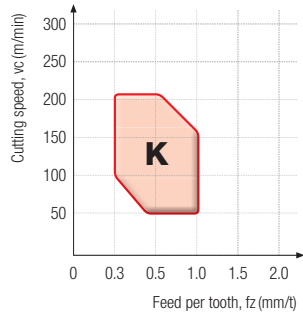

S HRSA

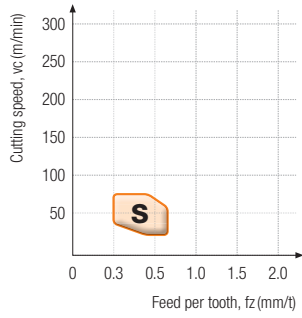

[HFMD10]

P Steel

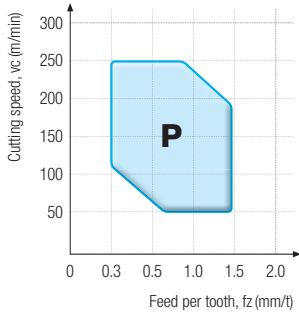

M Stainless steel

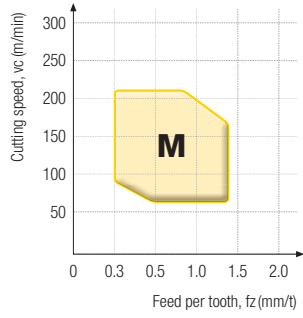

K Cast iron

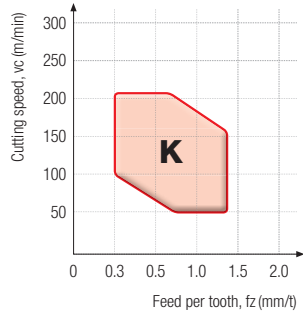

S HRSA

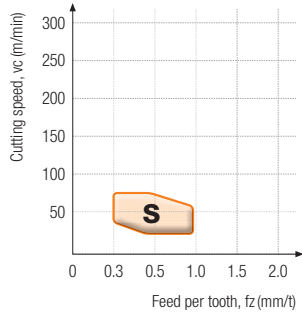

✓ Cutting performance

Carbon steel (C45, HB200)

Workpiece Steel rectangular tube (300 × 200 × 100)

Cutting conditions vc (m/min) = 200, fz (mm/t) = 1.2, ap (mm) = 0.8, ae (mm) = 20, dry

Tools **Insert** LNMX060310R-MF (PC5300) **Holder** HFMS032R-5C32-200-LN06

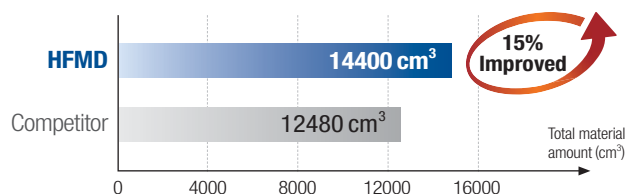

- Material removal rate Q (cm³/min): 191.0
- Cutting time (min): 75.4

Alloy tool steel (X40CrMoV5-1, HRC40 ~ 45)

(*: DIN)

Workpiece Steel rectangular tube (300 × 200 × 100)

Cutting conditions vc (m/min) = 160, fz (mm/t) = 1.2, ap (mm) = 0.9, ae (mm) = 20, dry

Tools **Insert** LNMX100412R-MF (PC2510) **Holder** HFMS032R-4C32-200-LN10

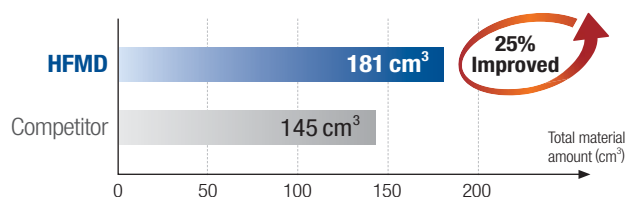

- Material removal rate Q (cm³/min): 91.7
- Cutting time (min): 2.0

Stainless steel (X5CrNi18-10, HB200)

Workpiece Steel rectangular tube (300 × 200 × 100)

Cutting conditions vc (m/min) = 150, fz (mm/t) = 0.6, ap (mm) = 0.4, ae (mm) = 10, dry

Tools **Insert** LNMX040205R-ML (PC5300) **Holder** HFMS016R-4C16-150-LN04

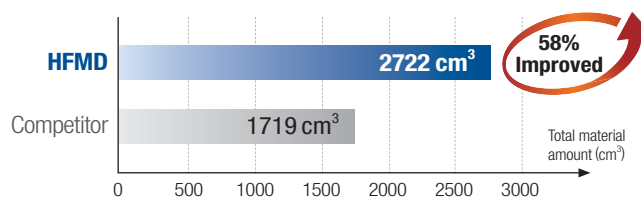

- Material removal rate Q (cm³/min): 28.6
- Cutting time (min): 93

Application examples

Carbon steel (C45, HB200)

Workpiece	Machine parts
Cutting conditions	vc (m/min) = 157, fz (mm/t) = 0.43, ap (mm) = 0.5, ae (mm) = 20 ~ 50, dry
Tools	Insert LNMX100412R-MF (PC2510) Holder HFMDCM050R-22-7-LN10

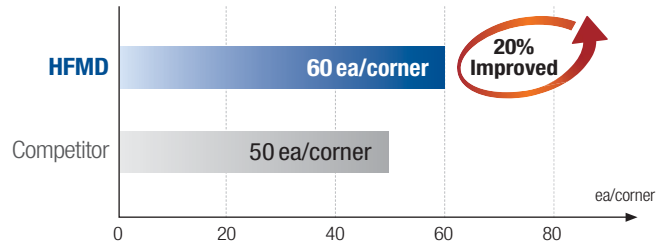

» 20% longer tool life than existing items

Alloy tool steel (1.2714*, HRC37~38)

(*: DIN)

Workpiece	Pipe
Cutting conditions	vc (m/min) = 130, fz (mm/t) = 1.2, ap (mm) = 0.3, ae (mm) = 30, dry
Tools	Insert LNMX060310R-MF (PC3700) Holder HFMDCM040R-16-6-LN06

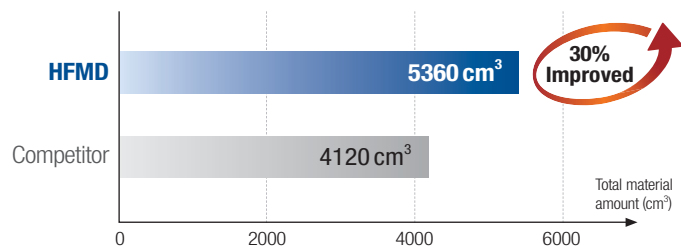

» 30% longer tool life and 10% higher productivity than existing items

HRSA (15156-3, HRC40)

Workpiece	Aircrafts parts
Cutting conditions	vc (m/min) = 80, fz (mm/t) = 0.2, ap (mm) = 0.5, ae (mm) = 11, wet
Tools	Insert LNMX060310R-ML (UPC845) Holder HFMS017R-2C16-200-LN06

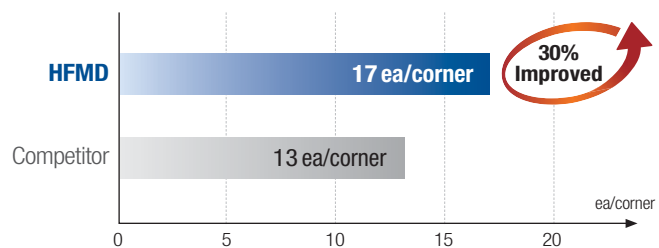

» 30% longer tool life than existing items

Ramping and helical cutting

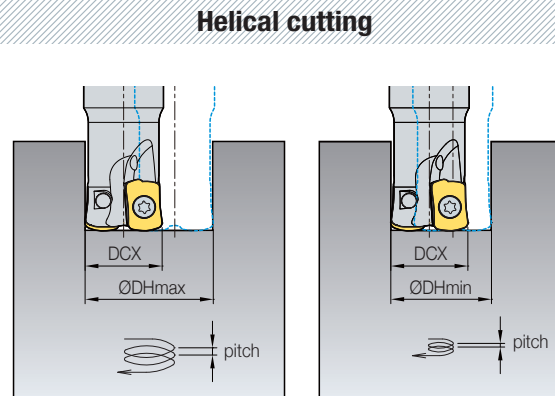
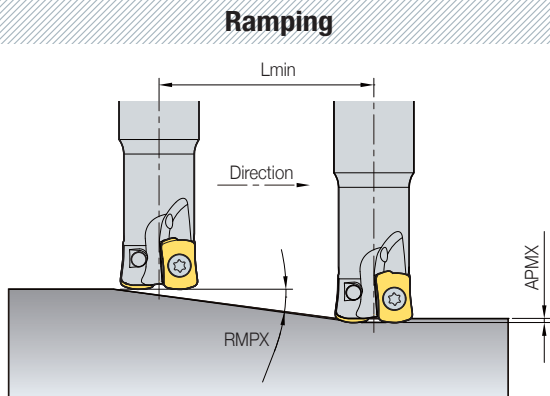

(mm)

Designation	Tool dia. DCX	Depth of cut APMX	Ramping		Blind hole helical cutting				Through hole helical cutting	
			Max. rake angle RMPX	Lmin	Max. machining dia. ØDHmax	Max. pitch	Min. machining dia. ØDHmin	Max. pitch	Min. machining dia. ØDHmin	Max. pitch
LNMX04	8	0.4	0.5	45	12	0.2	10	0.2	9	0.2
	10	0.4	0.6	37	16	0.3	14	0.3	13	0.3
	11	0.5	0.8	37	18	0.3	15	0.3	15	0.3
	12	0.5	1.0	28	20	0.4	17	0.4	17	0.4
	13	0.5	1.0	27	22	0.4	19	0.4	19	0.4
	16	0.5	1.0	28	28	0.5	25	0.5	25	0.5
	17	0.5	1.0	29	30	0.5	27	0.5	27	0.5
	20	0.5	0.9	33	36	0.5	33	0.5	33	0.5
	21	0.5	0.7	44	38	0.5	35	0.5	35	0.5
	25	0.5	0.7	43	46	0.5	43	0.5	43	0.5
	32	0.5	0.5	57	60	0.5	57	0.5	57	0.5
33	0.5	0.4	74	62	0.5	59	0.5	59	0.5	
35	0.5	0.4	79	66	0.5	63	0.5	63	0.5	
LNMX06	16	0.7	3.0	13	30	0.7	22	0.7	21	0.7
	17	1.0	2.3	25	32	1.0	24	1.0	22	1.0
	18	1.0	2.1	27	34	1.0	26	1.0	24	1.0
	19	1.0	1.9	30	36	1.0	28	1.0	26	1.0
	20	1.0	1.5	37	38	1.0	30	1.0	28	1.0
	21	1.0	1.5	39	40	1.0	32	1.0	30	1.0
	25	1.0	1.4	40	48	1.0	40	1.0	38	1.0
	26	1.0	1.4	42	50	1.0	42	1.0	40	1.0
	30	1.0	1.1	51	58	1.0	50	1.0	48	1.0
	32	1.0	1.0	55	62	1.0	54	1.0	52	1.0
	33	1.0	1.0	57	64	1.0	56	1.0	54	1.0
	35	1.0	0.9	61	68	1.0	60	1.0	58	1.0
	40	1.0	0.8	71	78	1.0	70	1.0	68	1.0
	42	1.0	0.8	76	82	1.0	74	1.0	72	1.0
50	1.0	0.6	92	98	1.0	90	1.0	88	1.0	
52	1.0	0.6	96	102	1.0	94	1.0	92	1.0	
63	1.0	0.5	119	124	1.0	116	1.0	114	1.0	
66	1.0	0.5	126	130	1.0	122	1.0	120	1.0	
LNMX10	25	1.5	2.9	30	42	1.5	35	1.5	32	1.5
	26	1.5	2.7	32	44	1.5	37	1.5	34	1.5
	30	1.5	2.2	39	52	1.5	45	1.5	42	1.5
	32	1.5	2.0	43	56	1.5	49	1.5	46	1.5
	33	1.5	1.9	45	58	1.5	51	1.5	48	1.5
	35	1.5	1.8	49	62	1.5	55	1.5	52	1.5
	40	1.5	1.5	58	72	1.5	65	1.5	62	1.5
	42	1.5	1.4	62	76	1.5	69	1.5	66	1.5
	50	1.5	1.1	77	92	1.5	85	1.5	82	1.5
	52	1.5	1.1	81	96	1.5	89	1.5	86	1.5
	63	1.5	0.8	101	118	1.5	111	1.5	108	1.5
	66	1.5	0.8	107	124	1.5	117	1.5	114	1.5
	80	1.5	0.6	133	152	1.5	145	1.5	142	1.5
100	1.5	0.5	171	192	1.5	185	1.5	182	1.5	

- When ramping and helical milling, table feed, vf (mm/min) should be lower than 70% of the recommended cutting conditions.
- When helical milling, Max. pitch, DHmax should be lower than max. depth of cut, APMX.
- When ramping, the depth of cut should be lower than max. depth of cut, APMX.

- $Lmin = APMX / \tan(RMPX)$ (mm)
- Lmin: Min. length of ramping
- APMX: Depth of cut
- RMPX: Max. rake angle in ramping

Caution for corner R programming

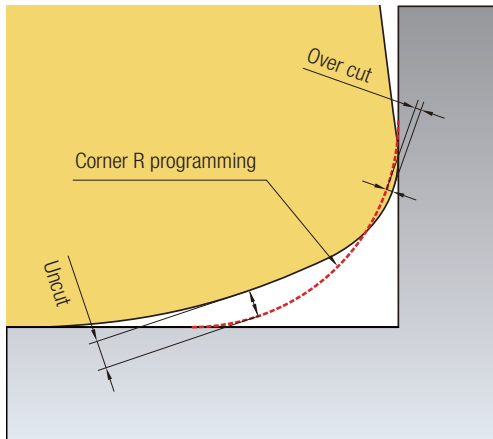

----- Corner R programming

Insert	Corner R programming	Cutting conditions		Over cut	Uncut
		Nose R RE	Max. APMX		
LNMX040205R-ML LNMX040205R-MM	R0.8	0.5	0.5	0.00	0.27
	R0.9 (Standard)			0.00	0.24
	R1.0			0.01	0.22
LNMX060310R-ML LNMX060310R-MF LNMX060310R-MM	R1.5	1.0	1.0	0.00	0.41
	R1.6 (Standard)			0.00	0.41
	R2.0			0.06	0.38
LNMX100412R-ML LNMX100412R-MF LNMX100412R-MM	R2.0	1.2	1.5	0.00	0.84
	R2.5 (Standard)			0.00	0.60
	R3.0			0.06	0.51

- During usage of CNC program, over cut & uncut would be occurred on the corner processing site if entering the correct program corner R value for each insert.
- To prevent overcut, you will need to complete a CNC program considering the above overcut.

Insert

Picture	Designation	Coated							Dimensions (mm)				Geometries	
		PC2505	PC2510	PC3700	PC9540	PC5300	PC5400	UNC840	UPC845	INSL	W1	S		RE
	LNMX 040205R-ML					●	●	●	●	6.2	4.2	2.35	0.5	
	060310R-ML					●	●	●	●	10.0	6.8	3.60	1.0	
	100412R-ML					●	●	●	●	12.2	10.0	4.20	1.2	
	LNMX 060310R-MF		●	●		●	●	●	●	10.0	6.8	3.60	1.0	
	100412R-MF		●	●	●	●	●	●	●	12.2	10.0	4.20	1.2	
	LNMX 040205R-MM		●	●		●	●		●	6.2	4.2	2.35	0.5	
	060310R-MM		●	●		●	●			10.0	6.8	3.60	1.0	
	100412R-MM		●	●		●	●			12.2	10.0	4.20	1.2	

●: Stock item

HFMD5-LN04



• AR: -8°~ -7°
• RR: -19°~ -15°

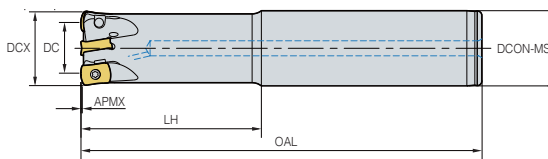

(mm)

Designation	Stock		DCX	DC	DCON-MS	LH	OAL	APMX	
HFMD5 008NR-1C08-080-LN04		1	8	3.68	8	20	80	0.4	0.03
008NR-1C10-100-LN04		1	8	3.68	10	20	100	0.4	0.05
010NR-2C08-080-LN04		2	10	5.68	8	20	80	0.4	0.03
010NR-2C10-100-LN04		2	10	5.68	10	20	100	0.4	0.06
010NR-2C10-150-LN04		2	10	5.68	10	40	150	0.4	0.08
011NR-2C10-100-LN04		2	11	6.68	10	20	100	0.5	0.06
011NR-2C10-150-LN04		2	11	6.68	10	20	150	0.5	0.09
008R-1C08-080-LN04		1	8	3.68	8	35	80	0.5	0.02
008R-1C10-100-LN04	●	1	8	3.68	10	20	100	0.5	0.05
010R-2C08-080-LN04	●	2	10	5.68	8	20	80	0.4	0.03
010R-2C10-080-LN04	●	2	10	5.68	10	35	80	0.4	0.05
010R-2C10-100-LN04	●	2	10	5.68	10	20	100	0.4	0.05
010R-2C10-150-LN04	●	2	10	5.68	10	40	150	0.4	0.07
011R-2C10-100-LN04		2	11	6.68	10	20	100	0.5	0.05
011R-2C10-150-LN04	●	2	11	6.68	10	20	150	0.5	0.08
012R-3C12-100-LN04	●	3	12	7.68	12	50	100	0.5	0.07
012R-3C12-105-LN04	●	3	12	7.68	12	20	105	0.5	0.07
012R-3C12-150-LN04	●	3	12	7.68	12	40	150	0.5	0.11

● : Stock item

Available inserts



LNMX-ML



LNMX-MM

Designation	Coated							
	PC2505	PC2510	PC3700	PC9540	PC5300	PC5400	UNC840	UPC845
LNMX 040205R-ML					●	●	●	●
040205R-MM		●	●		●	●		●

● : Stock item

Parts

Parts	Screw	Wrench
Specification		
Ø8 ~ Ø12	FTKA01844-A	TW06S-A

HFMD5-LN04



• AR: -8°
• RR: -14° ~ -13°

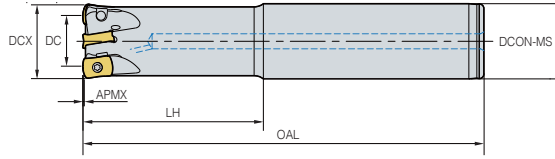

(mm)

Designation	Stock		DCX	DC	DCX-MS	LH	OAL	APMX	
HFMD5 013R-3C12-100-LN04		3	13	8.68	12	20	100	0.5	0.08
013R-3C12-120-LN04	●	3	13	8.68	12	20	120	0.5	0.09
013R-3C12-150-LN04	●	3	13	8.68	12	20	150	0.5	0.12
016R-4C16-100-LN04	●	4	16	11.68	16	50	100	0.5	0.13
016R-4C16-120-LN04	●	4	16	11.68	16	70	120	0.5	0.20
016R-4C16-150-LN04	●	4	16	11.68	16	80	150	0.5	0.20
016R-4C16-200-LN04	●	4	16	11.68	16	120	200	0.5	0.26
017R-4C16-100-LN04		4	17	12.68	16	20	100	0.5	0.14
017R-4C16-150-LN04	●	4	17	12.68	16	20	150	0.5	0.20
017R-4C16-200-LN04	●	4	17	12.68	16	20	200	0.5	0.29
020R-5C20-100-LN04	●	5	20	15.68	20	20	100	0.5	0.22
020R-5C20-150-LN04	●	5	20	15.68	20	40	150	0.5	0.30
020R-5C20-200-LN04	●	5	20	15.68	20	80	200	0.5	0.40
021R-5C20-100-LN04		5	21	16.68	20	20	100	0.5	0.22
021R-5C20-150-LN04	●	5	21	16.68	20	20	150	0.5	0.30
021R-5C20-200-LN04	●	5	21	16.68	20	20	200	0.5	0.46

●: Stock item

Available inserts



LNMX-ML



LNMX-MM

Designation	Coated							
	PC2505	PC2510	PC3700	PC9540	PC5300	PC5400	UNC840	UPC845
LNMX 040205R-ML					●	●	●	●
040205R-MM		●	●		●	●		●

●: Stock item

Parts

Parts	Screw	Wrench
Specification		
Ø13 ~ Ø21	FTKA01844-A	TW06S-A

HFMD5-LN06



• AR: -9°
• RR: -14° ~ -13°

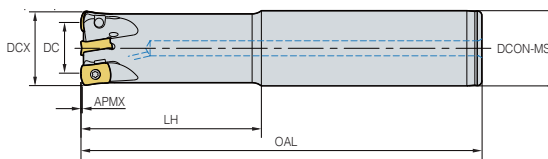

(mm)

Designation	Stock		DCX	DC	DCON-MS	LH	OAL	APMX	
HFMD5 016R-2C16-100-LN06	●	2	16	9.0	16	30	100	0.7	0.13
016R-2C16-150-LN06	●	2	16	8.6	16	50	150	0.7	0.19
017R-2C16-100-LN06	●	2	17	9.6	16	30	100	1.0	0.13
017R-2C16-150-LN06	●	2	17	9.6	16	40	150	1.0	0.20
017R-2C16-200-LN06		2	17	9.6	16	40	200	1.0	0.27
018R-2C16-100-LN06		2	18	10.6	16	40	100	1.0	0.14
018R-2C16-160-LN06		2	18	10.6	16	40	160	1.0	0.18
018R-2C16-200-LN06		2	18	10.6	16	40	200	1.0	0.28
019R-2C16-100-LN06		2	19	11.6	16	40	100	1.0	0.15
019R-2C16-160-LN06		2	19	11.6	16	40	160	1.0	0.19
019R-2C16-200-LN06		2	19	11.6	16	40	200	1.0	0.29
020R-3C20-100-LN06		3	20	12.6	20	40	100	1.0	0.20
020R-3C20-130-LN06	●	3	20	12.6	20	50	130	1.0	0.26
020R-3C20-160-LN06	●	3	20	12.6	20	80	160	1.0	0.31
020R-3C20-200-LN06	●	3	20	12.6	20	120	200	1.0	0.10
021R-3C20-100-LN06		3	21	13.6	20	30	100	1.0	0.21
021R-3C20-130-LN06		3	21	13.6	20	40	130	1.0	0.27
021R-3C20-160-LN06	●	3	21	13.6	20	40	160	1.0	0.34
021R-3C20-200-LN06	●	3	21	13.6	20	40	200	1.0	0.42

●: Stock item

Available inserts



LNMX-ML



LNMX-MF



LNMX-MM

Designation	Coated							
	PC2505	PC2510	PC3700	PC9540	PC5300	PC5400	UNC840	UPC845
LNMX 060310R-ML					●	●	●	●
060310R-MF		●	●		●	●	●	●
060310R-MM		●	●		●	●		

●: Stock item

Parts

Parts	Screw	Wrench
Specification Ø16 ~ Ø21	 FTNA0306	 TW09S

HFMD5-LN06



• AR: -9°
• RR: -12° ~ -10°

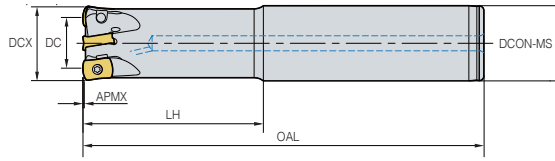

(mm)										
	Designation	Stock		DCX	DC	DCON-MS	LH	OAL	APMX	
HFMD5	025R-4C25-100-LN06	●	4	25	17.6	25	40	100	1.0	0.33
	025R-4C25-140-LN06	●	4	25	17.6	25	60	140	1.0	0.46
	025R-4C25-180-LN06	●	4	25	17.6	25	100	180	1.0	0.58
	025R-4C25-250-LN06		4	25	17.6	25	150	250	1.0	0.67
	026R-4C25-100-LN06		4	26	18.6	25	30	100	1.0	0.34
	026R-4C25-140-LN06	●	4	26	18.6	25	40	140	1.0	0.48
	026R-4C25-180-LN06	●	4	26	18.6	25	40	180	1.0	0.63
	026R-4C25-250-LN06	●	4	26	18.6	25	40	250	1.0	0.72
	032R-5C32-150-LN06	●	5	32	24.6	32	70	150	1.0	0.82
	032R-5C32-200-LN06	●	5	32	24.6	32	120	200	1.0	1.08
	032R-5C32-250-LN06		5	32	24.6	32	150	250	1.0	1.20
	033R-5C32-150-LN06		5	33	25.6	32	40	150	1.0	0.82
	033R-5C32-200-LN06	●	5	33	25.6	32	40	200	1.0	1.08
	033R-5C32-250-LN06	●	5	33	25.6	32	40	250	1.0	1.20
	035R-5C32-150-LN06		5	35	27.6	32	40	150	1.0	0.87
	035R-5C32-200-LN06		5	35	27.6	32	40	200	1.0	1.13
	035R-5C32-250-LN06		5	35	27.6	32	40	250	1.0	1.25
	040R-6C32-150-LN06		6	40	32.6	32	40	150	1.0	0.97
	040R-6C32-200-LN06		6	40	32.6	32	40	200	1.0	1.28
	040R-6C32-250-LN06		6	40	32.6	32	40	250	1.0	1.38

●: Stock item

Available inserts



LNMX-ML



LNMX-MF



LNMX-MM

Designation	Coated							
	PC2505	PC2510	PC3700	PC9540	PC5300	PC5400	UNC840	UPC845
LNMX 060310R-ML					●	●	●	●
060310R-MF		●	●		●	●	●	●
060310R-MM		●	●		●	●		

●: Stock item

Parts

Parts	Screw	Wrench
Specification		
Ø25 ~ Ø40	FTNA0306	TW09S

HFMD5-LN10



• AR: -9°
• RR: -16° ~ -13°

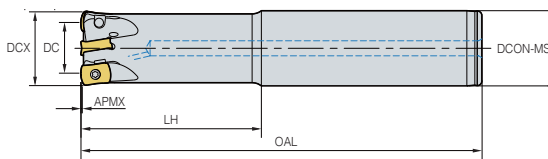

(mm)

	Designation	Stock		DCX	DC	DCON-MS	LH	OAL	APMX		
HFMD5	025R-2C25-150-LN10	●	2	25	14	25	70	150	1.5	0.46	
	025R-2C25-200-LN10	●	2	25	14	25	100	200	1.5	0.60	
	025R-3C25-150-LN10	●	3	25	14	25	70	150	1.5	0.45	
	025R-3C25-200-LN10	●	3	25	14	25	100	200	1.5	0.60	
	026R-3C25-150-LN10	●	3	26	15	25	40	150	1.5	0.49	
	026R-3C25-200-LN10	●	3	26	15	25	40	200	1.5	0.68	
	030R-3C32-150-LN10	●	3	30	19	32	70	150	1.5	0.71	
	030R-3C32-200-LN10	●	3	30	19	32	100	200	1.5	0.94	
	032R-4C32-150-LN10	●	4	32	21	32	70	150	1.5	0.75	
	032R-4C32-200-LN10	●	4	32	21	32	100	200	1.5	1.00	
	032R-4C32-250-LN10	●	4	32	21	32	150	250	1.5	1.20	
	033R-4C32-150-LN10	●	4	33	22	32	40	150	1.5	0.80	
	033R-4C32-200-LN10	●	4	33	22	32	40	200	1.5	1.00	
	033R-4C32-250-LN10	●	4	33	22	32	40	250	1.5	1.40	
	035R-4C32-150-LN10			4	35	24	32	40	150	1.5	0.85
	035R-4C32-200-LN10			4	35	24	32	40	200	1.5	1.10
	035R-4C32-250-LN10			4	35	24	32	40	250	1.5	1.44
	040R-4C32-150-LN10			4	40	29	32	40	150	1.5	0.89
	040R-4C32-200-LN10			4	40	29	32	40	200	1.5	1.20
	040R-4C32-250-LN10	●		4	40	29	32	40	250	1.5	1.48
	040R-5C32-150-LN10			5	40	29	32	40	150	1.5	0.89
	040R-5C32-200-LN10			5	40	29	32	40	200	1.5	1.19
	040R-5C32-250-LN10	●		5	40	29	32	40	250	1.5	1.48
	042R-5C32-150-LN10			5	42	31	32	40	150	1.5	0.92
	042R-5C32-200-LN10			5	42	31	32	40	200	1.5	1.23
	042R-5C32-250-LN10	●		5	42	31	32	40	250	1.5	1.51

●: Stock item

Available inserts



LNMX-ML



LNMX-MF



LNMX-MM

Designation	Coated							
	PC2505	PC2510	PC3700	PC9540	PC5300	PC5400	UNC840	UPC845
LNMX 100412R-ML				●	●	●	●	●
100412R-MF		●	●	●	●	●	●	●
100412R-MM		●	●		●	●		

●: Stock item

Parts

Parts	Screw	Wrench
Specification		
Ø25 ~ Ø42	FTNA0408	TW15S

HFMDCM-LN06



• AR: -9°
• RR: -12° ~ -10°

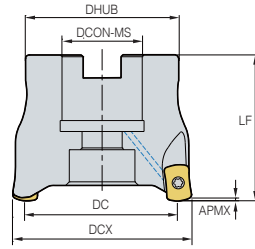
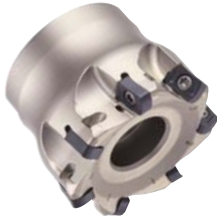

(mm)

	Designation	Stock		DCX	DC	DHUB	DCON-MS	LF	APMX	
HFMDCM	032R-16-5-LN06		5	32	24.6	30	16	40	1.0	0.12
	040R-16-6-LN06	●	6	40	32.6	34	16	40	1.0	0.21
	050R-22-6-LN06		6	50	42.6	42	22	40	1.0	0.32
	050R-22-7-LN06		7	50	42.6	42	22	40	1.0	0.32
	050R-22-8-LN06	●	8	50	42.6	42	22	40	1.0	0.32
	052R-22-7-LN06		7	52	44.6	42	22	40	1.0	0.34
	052R-22-8-LN06		8	52	44.6	42	22	40	1.0	0.34
	063R-22-8-LN06		8	63	55.6	49	22	40	1.0	0.53
	063R-22-9-LN06	●	9	63	55.6	49	22	40	1.0	0.53
	066R-22-8-LN06		8	66	58.6	49	22	40	1.0	0.57
	066R-22-9-LN06		9	66	58.6	49	22	40	1.0	0.57

●: Stock item

Available inserts



LNMX-ML



LNMX-MF



LNMX-MM

Designation	Coated							
	PC2505	PC2510	PC3700	PC9540	PC5300	PC5400	UNC840	UPC845
LNMX 060310R-ML					●	●	●	●
060310R-MF		●	●		●	●	●	●
060310R-MM		●	●		●	●		

●: Stock item

Available arbors

Designation	DCON	Available arbors
HFMDCM 032R-16-□-LN06	Ø16	BT□□-FMC16-□□
040R-16-□-LN06		
050R-22-□-LN06	Ø22	BT□□-FMC22-□□

Designation	DCON	Available arbors
HFMDCM 052R-22-□-LN06	Ø22	BT□□-FMC22-□□
063R-22-□-LN06		
066R-22-□-LN06		

Parts

Parts	Screw	Wrench
Specification		
Ø32 ~ Ø66	FTNA0306	TW09S

HFMD C(M)-LN10



• AR: -9°
• RR: -16° ~ -13°

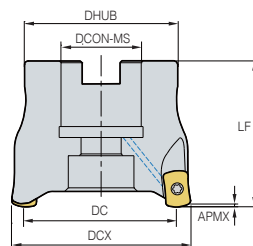

(mm)

Designation	Stock		DCX	DC	DHUB	DCON-MS	LF	APMX		
HFMDCM	040R-16-4-LN10		4	40	29	38	16.00	40	1.5	0.19
	040R-16-5-LN10	●	5	40	29	38	16.00	40	1.5	0.19
	042R-16-4-LN10		4	42	31	38	16.00	40	1.5	0.20
	042R-16-5-LN10	●	5	42	31	38	16.00	40	1.5	0.20
	050R-22-6-LN10	●	6	50	39	42	22.00	40	1.5	0.26
	050R-22-7-LN10	●	7	50	39	42	22.00	40	1.5	0.26
	052R-22-6-LN10		6	52	41	42	22.00	40	1.5	0.27
	052R-22-7-LN10	●	7	52	41	42	22.00	40	1.5	0.27
	063R-22-7-LN10	●	7	63	52	49	22.00	40	1.5	0.47
	063R-22-8-LN10	●	8	63	52	49	22.00	40	1.5	0.47
	066R-22-7-LN10		7	66	55	49	22.00	40	1.5	0.49
	066R-22-8-LN10	●	8	66	55	49	22.00	40	1.5	0.50
	080R-27-9-LN10		9	80	69	60	27.00	50	1.5	0.84
	080R-27-10-LN10	●	10	80	69	60	27.00	50	1.5	0.84
100R-32-10-LN10		10	100	89	67	32.00	56	1.5	1.48	
100R-32-11-LN10	●	11	100	89	67	32.00	56	1.5	1.48	
100R-32-12-LN10		12	100	89	67	32.00	56	1.5	1.48	
HFMD C	080R-25.4-9-LN10		9	80	69	60	25.40	50	1.5	0.84
	080R-25.4-10-LN10		10	80	69	60	25.40	50	1.5	0.84
	100R-31.75-10-LN10		10	100	89	67	31.75	56	1.5	1.48
	100R-31.75-11-LN10		11	100	89	67	31.75	56	1.5	1.48
	100R-31.75-12-LN10		12	100	89	67	31.75	56	1.5	1.48

●: Stock item

Available inserts



LNMX-ML



LNMX-MF



LNMX-MM

Designation	Coated							
	PC2505	PC2510	PC3700	PC9540	PC5300	PC5400	UNC840	UPC845
LNMX	100412R-ML			●	●	●	●	●
	100412R-MF		●	●	●	●	●	●
	100412R-MM		●	●	●	●	●	●

●: Stock item

Available arbors

Designation	DCON	Available arbors	Designation	DCON	Available arbors
HFMDCM	Ø16	BT□□-FMC16-□□	066R-22-□-LN10	Ø22	BT□□-FMC22-□□
			080R-27-□-LN10	Ø27	BT□□-FMC27-□□
	Ø22	BT□□-FMC22-□□	100R-32-□-LN10	Ø32	BT□□-FMC32-□□
			080R-25.4-□-LN10	Ø25.4	BT□□-FMA25.4-□□
063R-22-□-LN10			100R-31.75-□-LN10	Ø31.75	BT□□-FMA31.75-□□

Parts

Parts	Screw	Wrench
Specification		
Ø40 ~ Ø100	FTNA0408	TW15S

HFMDM-LN04



• AR: -8°
• RR: -16° ~ -10°

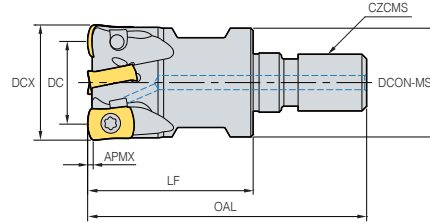

(mm)

Designation	Stock		DCX	DC	DCON-MS	LF	OAL	CZCMS	APMX	
HFMDM 010R-2-M06-LN04	●	2	10	5.68	9.5	22	37	M6	0.4	0.01
011R-2-M06-LN04	●	2	11	6.68	11.0	22	37	M6	0.5	0.01
012R-3-M06-LN04	●	3	12	7.68	11.0	22	37	M6	0.5	0.01
013R-3-M06-LN04	●	3	13	8.68	11.0	22	37	M6	0.5	0.02
016R-4-M08-LN04	●	4	16	11.68	14.5	22	39	M8	0.5	0.03
017R-4-M08-LN04	●	4	17	12.68	14.5	22	39	M8	0.5	0.03
020R-5-M10-LN04	●	5	20	15.68	18.0	30	51	M10	0.5	0.06
025R-7-M12-LN04	●	7	25	20.68	23.0	30	54	M12	0.5	0.10
032R-8-M16-LN04	●	8	32	27.68	29.0	35	62	M16	0.5	0.20
033R-8-M16-LN04	●	8	33	28.68	29.0	35	62	M16	0.5	0.20
035R-9-M16-LN04	●	9	35	30.68	29.0	35	62	M16	0.5	0.21

●: Stock item

Available inserts



LNMX-ML



LNMX-MM

Designation	Coated							
	PC2505	PC2510	PC3700	PC9540	PC5300	PC5400	UNC840	UPC845
LNMX 040205R-ML					●	●	●	●
040205R-MM		●	●		●	●		●

●: Stock item

Available adapter

Designation	Available adapter
HFMDM 010R-□-M06-LN04	MAT-M06
011R-□-M06-LN04	
012R-□-M06-LN04	
013R-□-M06-LN04	
016R-□-M08-LN04	MAT-M08
017R-□-M08-LN04	

Designation	Available adapter
HFMDM 020R-□-M10-LN04	MAT-M10
025R-□-M12-LN04	MAT-M12
032R-□-M16-LN04	MAT-M16
033R-□-M16-LN04	
035R-□-M16-LN04	

Designation:
HFMDM016R-□-M08-LN04
Modular head threading
measure size (M08)

II

Adapter spec: MAT-M08-040-S16T
Adapter threading measure (M08)

Parts

Parts	Screw	Wrench
Specification Ø10 ~ Ø35	 FTKA01844-A	 TW06S-A

HFMDM-LN06



• AR: -9°
• RR: -15° ~ -10°

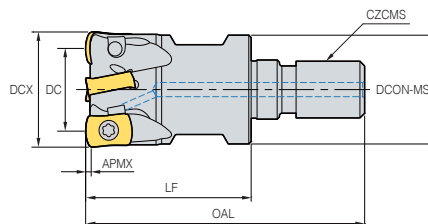

(mm)

Designation	Stock		DCX	DC	DCON-MS	LF	OAL	CZCMS	APMX	
HFMDM 016R-2-M08-LN06	●	2	16	8.6	14.5	25	42	M08	0.7	0.03
017R-2-M08-LN06	●	2	17	9.6	14.5	25	42	M08	1.0	0.03
018R-2-M08-LN06		2	18	10.6	14.5	25	42	M08	1.0	0.04
019R-2-M08-LN06		2	19	11.6	14.5	25	42	M08	1.0	0.05
020R-3-M10-LN06	●	3	20	12.6	18.0	30	51	M10	1.0	0.06
021R-3-M10-LN06	●	3	21	13.6	18.0	30	51	M10	1.0	0.07
025R-4-M12-LN06	●	4	25	17.6	23.0	35	59	M12	1.0	0.10
026R-4-M12-LN06		4	26	18.6	23.0	35	59	M12	1.0	0.10
032R-5-M16-LN06	●	5	32	24.6	29.0	40	67	M16	1.0	0.20
033R-5-M16-LN06		5	33	25.6	29.0	40	67	M16	1.0	0.20
035R-5-M16-LN06	●	5	35	27.6	29.0	40	67	M16	1.0	0.21
040R-6-M16-LN06		6	40	32.6	29.0	40	67	M16	1.0	0.24
042R-6-M16-LN06		6	42	34.6	29.0	40	67	M16	1.0	0.25

● : Stock item

Available inserts



LNX-ML



LNX-MF



LNX-MM

Designation	Coated							
	PC2505	PC2510	PC3700	PC9540	PC5300	PC5400	UNC840	UPC845
LNX 060310R-ML					●	●	●	●
060310R-MF		●	●		●	●	●	●
060310R-MM		●	●		●	●		

● : Stock item

Available adapter

Designation	Available adapter	Designation	Available adapter
HFMDM 016R-□-M08-LN06	MAT-M08	HFMDM 026R-□-M12-LN06	MAT-M12
017R-□-M08-LN06		030R-□-M16-LN06	MAT-M16
018R-□-M08-LN06		032R-□-M16-LN06	
019R-□-M08-LN06		033R-□-M16-LN06	
020R-□-M10-LN06	035R-□-M16-LN06		
021R-□-M10-LN06	040R-□-M16-LN06		
025R-□-M12-LN06	MAT-M12	042R-□-M16-LN06	

Designation:
HFMDM025R-□-M12-LN06
Modular head threading
measure size (M12)

||

Adapter spec: MAT-M12-050-S25T
Adapter threading measure (M12)

Parts

Parts	Screw	Wrench
Specification Ø16 ~ Ø42	 FTNA0306	 TW09S

HFMDM-LN10



• AR: -9°
• RR: -16° ~ -13°

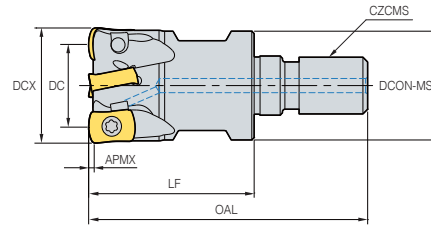

(mm)

	Designation	Stock		DCX	DC	DCON-MS	LF	OAL	CZCMS	APMX	
HFMDM	025R-2-M12-LN10	●	2	25	14	23	35	59	M12	1.5	0.10
	025R-3-M12-LN10	●	3	25	14	23	35	59	M12	1.5	0.10
	026R-3-M12-LN10	●	3	26	15	23	35	59	M12	1.5	0.10
	030R-4-M16-LN10	●	4	30	19	29	40	67	M16	1.5	0.17
	032R-3-M16-LN10		3	32	21	29	40	67	M16	1.5	0.19
	032R-4-M16-LN10	●	4	32	21	29	40	67	M16	1.5	0.19
	033R-4-M16-LN10	●	4	33	22	29	40	67	M16	1.5	0.19
	035R-3-M16-LN10		3	35	24	29	40	67	M16	1.5	0.20
	035R-4-M16-LN10	●	4	35	24	29	40	67	M16	1.5	0.20
	040R-4-M16-LN10		4	40	29	29	40	67	M16	1.5	0.22
	040R-5-M16-LN10	●	5	40	29	29	40	67	M16	1.5	0.22
	042R-4-M16-LN10		4	42	31	29	40	67	M16	1.5	0.25
	042R-5-M16-LN10	●	5	42	31	29	40	67	M16	1.5	0.25

●: Stock item

Available inserts

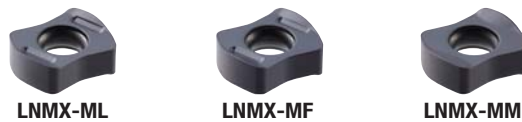

Designation	Coated							
	PC2505	PC2510	PC3700	PC9540	PC5300	PC5400	UNC840	UPC845
LNMX 100412R-ML				●	●	●	●	●
100412R-MF		●	●	●	●	●	●	●
100412R-MM		●	●		●	●		

●: Stock item

Available adapter

Designation	Available adapter
HFMDM 025R-□-M12-LN10	MAT-M12
026R-□-M12-LN10	
030R-□-M16-LN10	MAT-M16
032R-□-M16-LN10	

Designation	Available adapter
HFMDM 033R-□-M16-LN10	MAT-M16
035R-□-M16-LN10	
040R-□-M16-LN10	
042R-□-M16-LN10	

Designation:
HFMDM035R-□-M16-LN10
Modular head threading
measure size (M16)

II

Adapter spec: MAT-M16-035-S32S
Adapter threading measure (M16)

Parts

Parts	Screw	Wrench
Specification Ø25 ~ Ø42	 FTNA0408	 TW15S

MAT (Steel Shank type)

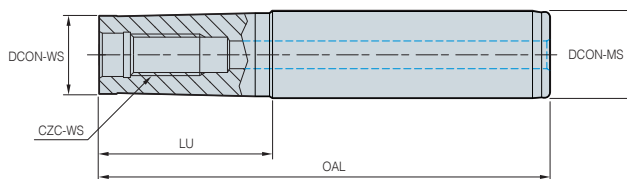

(mm)

Designation	Stock	DCON-WS	DCON-MS	LU	OAL	CZC-WS
MAT- M06-020-S10S	●	9.5	10	20	70	M06
M06-040-S12T	●	9.5	12	40	96	M06
M06-065-S16T	●	9.5	16	65	125	M06
M6B-020-S12S	●	11.0	12	20	76	M06
M6B-040-S12S	●	11.0	12	40	96	M06
M6B-065-S16T	●	11.0	16	65	125	M06
M6B-080-S16T	●	11.0	16	80	140	M06
M08-020-S16S	●	14.5	16	20	80	M08
M08-040-S16T	●	14.5	16	40	100	M08
M08-065-S16T	●	14.5	16	65	125	M08
M08-080-S20T	●	14.5	20	80	150	M08
M08-110-S25T	●	14.5	25	110	190	M08
M10-030-S20S	●	18.0	20	30	100	M10
M10-050-S20T	●	18.0	20	50	120	M10
M10-070-S20T	●	18.0	20	70	140	M10
M10-090-S25T	●	18.0	25	90	170	M10
M10-110-S25T	●	18.0	25	110	190	M10
M10-130-S32T	●	18.0	32	130	220	M10
M12-030-S25S	●	22.5	25	29	110	M12
M12-050-S25T	●	22.5	25	50	130	M12
M12-070-S25T	●	22.5	25	70	150	M12
M12-090-S25T	●	22.5	25	90	170	M12
M12-110-S32T	●	22.5	32	110	200	M12
M12-175-S40T	●	22.5	40	175	300	M12
M16-035-S32S	●	28.5	32	35	125	M16
M16-055-S32T	●	28.5	32	55	145	M16
M16-080-S32T	●	28.5	32	80	170	M16
M16-120-S32T	●	28.5	32	120	210	M16
M16-175-S40T	●	28.5	40	175	300	M16

* S: Straight neck adapter * T: Taper neck adapter

●: Stock item

MAT-C (Carbide Shank type)

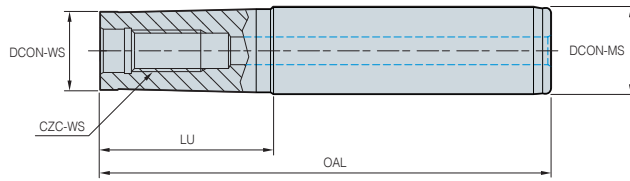

(mm)

Designation	Stock	DCÓN-WS	DCÓN-MS	LU	OAL	CZC-WS
MAT- M06-030-S10S-C-80		9.5	10	30	80	M06
M06-050-S10S-C-100		9.5	10	50	100	M06
M06-080-S10S-C-130		9.5	10	80	130	M06
M6B-030-S12S-C-80		11.0	12	30	80	M06
M6B-050-S12S-C-100		11.0	12	50	100	M06
M6B-080-S12S-C-130		11.0	12	80	130	M06
M08-080-S16S-C	●	14.5	16	80	150	M08
M08-110-S16S-C	●	14.5	16	110	180	M08
M08-150-S16S-C		14.5	16	150	250	M08
M08-010-S16S-C-150		14.5	16	10	150	M08
M08-010-S16S-C-180		14.5	16	10	180	M08
M08-010-S16S-C-250		14.5	16	10	250	M08
M10-090-S20S-C	●	18.0	20	90	170	M10
M10-110-S20S-C	●	18.0	20	110	200	M10
M10-175-S20S-C		18.0	20	175	300	M10
M10-010-S20S-C-170	●	18.0	20	10	170	M10
M10-010-S20S-C-200	●	18.0	20	10	200	M10
M10-010-S20S-C-300		18.0	20	10	300	M10
M12-090-S25S-C	●	22.5	25	90	170	M12
M12-110-S25S-C		22.5	25	110	200	M12
M12-175-S25S-C		22.5	25	175	300	M12
M12-015-S25S-C-170		22.5	25	15	170	M12
M12-015-S25S-C-200		22.5	25	15	200	M12
M12-015-S25S-C-300		22.5	25	15	300	M12
M16-090-S32S-C	●	28.5	32	90	180	M16
M16-120-S32S-C		28.5	32	120	210	M16
M16-175-S32S-C		28.5	32	175	300	M16
M16-020-S32S-C-180		28.5	32	20	180	M16
M16-020-S32S-C-210		28.5	32	20	210	M16
M16-020-S32S-C-300	●	28.5	32	20	300	M16

* S: Straight neck adapter * T: Taper neck adapter

●: Stock item

BT30/BT40/BT50

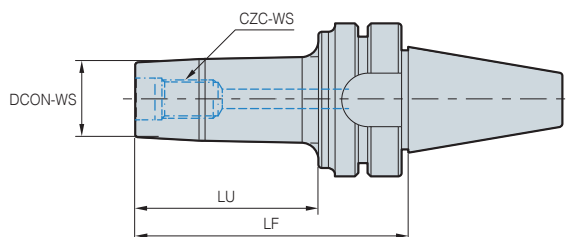

(mm)

	Designation	Stock	DCON-WS	LU	LF	CZC-WS
BT30-	MAT-M06-053		11.0	21	53	M06*1.0
	MAT-M08-057		14.5	25	57	M08*1.25
	MAT-M10-062		18.0	30	62	M10*1.5
	MAT-M12-067		23.0	35	67	M12*1.75
	MAT-M16-067		29.0	35	67	M16*2.0
BT40-	MAT-M06-062		11.0	25	62	M06*1.0
	MAT-M06-077		11.0	40	77	M06*1.0
	MAT-M06-092		11.0	55	92	M06*1.0
	MAT-M08-067		14.5	30	67	M08*1.25
	MAT-M08-082		14.5	45	82	M08*1.25
	MAT-M08-097		14.5	60	97	M08*1.25
	MAT-M10-072		18.0	35	72	M10*1.5
	MAT-M10-087		18.0	50	87	M10*1.5
	MAT-M10-102		18.0	65	102	M10*1.5
	MAT-M12-077		23.0	40	77	M12*1.75
	MAT-M12-092		23.0	55	92	M12*1.75
	MAT-M12-107		23.0	70	107	M12*1.75
	MAT-M16-077		29.0	40	77	M16*2.0
	MAT-M16-092		29.0	55	92	M16*2.0
	MAT-M16-107		29.0	70	107	M16*2.0
BT50-	MAT-M06-083		11.0	35	83	M06*1.0
	MAT-M06-098		11.0	50	98	M06*1.0
	MAT-M06-113		11.0	65	113	M06*1.0
	MAT-M08-088		14.5	40	88	M08*1.25
	MAT-M08-103		14.5	55	103	M08*1.25
	MAT-M08-118		14.5	70	118	M08*1.25
	MAT-M10-093		18.0	45	93	M10*1.5
	MAT-M10-113		18.0	65	113	M10*1.5
	MAT-M10-128		18.0	80	128	M10*1.5
	MAT-M12-103		23.0	55	103	M12*1.75
	MAT-M12-118		23.0	70	118	M12*1.75
	MAT-M12-133		23.0	85	133	M12*1.75
	MAT-M16-103		29.0	55	103	M16*2.0
	MAT-M16-118		29.0	70	118	M16*2.0
	MAT-M16-133		29.0	85	133	M16*2.0

● : Stock item

HSK63A/HSK100A

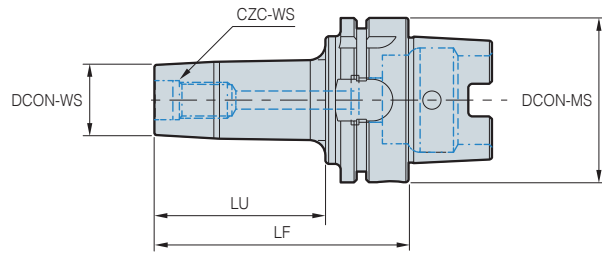

(mm)

	Designation	Stock	DCON-WS	DCON-MS	LU	LF	CZC-WS
HSK63A-	MAT-M06-061		11.0	63	25	61	M06*1.0
	MAT-M06-076		11.0	63	40	76	M06*1.0
	MAT-M06-091		11.0	63	55	91	M06*1.0
	MAT-M08-066		14.5	63	30	66	M08*1.25
	MAT-M08-081		14.5	63	45	81	M08*1.25
	MAT-M08-096		14.5	63	60	96	M08*1.25
	MAT-M10-071		18.0	63	35	71	M10*1.5
	MAT-M10-086		18.0	63	50	86	M10*1.5
	MAT-M10-101		18.0	63	65	101	M10*1.5
	MAT-M12-076		23.0	63	40	76	M12*1.75
	MAT-M12-091		23.0	63	55	91	M12*1.75
	MAT-M12-106		23.0	63	70	106	M12*1.75
	MAT-M16-076		29.0	63	40	76	M16*2.0
	MAT-M16-091		29.0	63	55	91	M16*2.0
MAT-M16-106		29.0	63	70	106	M16*2.0	
HSK100A-	MAT-M06-074		11.0	100	35	74	M06*1.0
	MAT-M06-089		11.0	100	50	89	M06*1.0
	MAT-M06-104		11.0	100	65	104	M06*1.0
	MAT-M08-079		14.5	100	40	79	M08*1.25
	MAT-M08-094		14.5	100	55	94	M08*1.25
	MAT-M08-109		14.5	100	70	109	M08*1.25
	MAT-M10-084		18.0	100	45	84	M10*1.5
	MAT-M10-104		18.0	100	65	104	M10*1.5
	MAT-M10-119		18.0	100	80	119	M10*1.5
	MAT-M12-094		23.0	100	55	94	M12*1.75
	MAT-M12-109		23.0	100	70	109	M12*1.75
	MAT-M12-124		23.0	100	85	124	M12*1.75
	MAT-M16-094		29.0	100	55	94	M16*2.0
	MAT-M16-109		29.0	100	70	109	M16*2.0
MAT-M16-124		29.0	100	85	124	M16*2.0	

● : Stock item

⚠ For the safe metalcutting

- Use safety supplies such as protective gloves to prevent possible injury while touching the edge of tools.
- Use safety glasses or safety cover to hedge possible dangers. Inappropriate usage or excessive cutting condition may lead tool's breakage or even the fragment's scattering.
- Clamp the workpiece tightly enough to prevent its movement while its machining.
- Properly manage the tool change phase because the inordinately used tool can be easily broken under the excessive cutting load or severe wear, and it may threat the operator's safety.
- Use safety cover because chips evacuated during cutting are hot and sharp and may cause burns and cuts. To remove chips safely, stop machining, put on protective gloves, and use a hook or other tools.
- Prepare for fire prevention measures as the use of the non-water soluble cutting oil may cause fire.
- Use safety cover and other safety supplies because the spare parts or the inserts can be pulled out due to centrifugal force while high speed machining.



Head Office: Holystar B/D, 1350, Nambusunhwan-ro, Geumcheon-gu, Seoul, 08536, Korea

Tel: +82-2-522-3181 Fax: +82-2-522-3184, +82-2-3474-4744 Web: www.korloy.com E-mail: sales.khq@korloy.com

New Company Building (Expected to move on June 2022): 326, Seocho-daero, Seocho-gu, Seoul, Republic of Korea

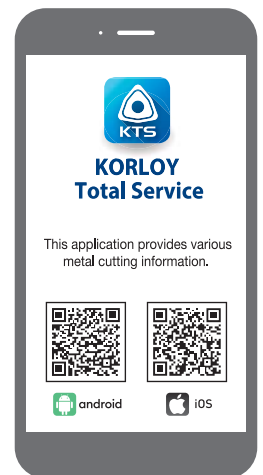

KORLOY AMERICA

620 Maple Avenue, Torrance, CA 90503, USA

Tel: +1-310-782-3800 Toll Free: +1-888-711-0001 Fax: +1-310-782-3885

E-mail: sales.kai@korloy.com

KORLOY INDIA

Plot No. 415, Sector 8, IMT Manesar, Gurgaon 122051, Haryana, India

Tel: +91-124-4391790 Fax: +91-124-4050032

E-mail: sales.kip@korloy.com

KORLOY TURKEY

Serifali Mahallesi, Burhan Sokak NO: 34

Dudullu OSB/Umraniye/Istanbul, 34775, Turkey

Tel: +90-216-415-8874 E-mail: sales.ktl@korloy.com

KORLOY RUSSIA

Krasivy Dom office No. 305, Bld. 5, Novovladykinskiy proezd 8, 127106, Moscow, Russia

Tel: +7-495-280-1458 Fax: +7-495-280-1459 E-mail: sales.krc@korloy.com

KORLOY FACTORY INDIA

Plot No. 415, Sector 8, IMT Manesar, Gurgaon 122051, Haryana, India

Tel: +91-124-4391790 Fax: +91-124-4050032

E-mail: pro.kim@korloy.com

KORLOY EUROPE

Gablonzer Str. 25-27, 61440 Oberursel, Germany

Tel: +49-6171-277-83-0 Fax: +49-6171-277-83-59

E-mail: sales.keg@korloy.com

KORLOY BRASIL

Av. Aruana 280, conj.12, WLC, Alphaville, Barueri,

CEP06460-010, SP, Brasil

Tel: +55-11-4193-3810 E-mail: sales.kbl@korloy.com

KORLOY CHILE

Av. Providencia 1650, Office 1009, 7500027

Providencia-Santiago, Chile

Tel: +56-229-295-490 E-mail: sales.kcs@korloy.com

KORLOY MEXICO

Queretaro, Mexico

E-mail: sales.kml@korloy.com

